

INSTALLATION INSTRUCTIONS

DESCRIPTION: Front Cargo Box Kit
 PART NUMBER: B16-F83P0-V0
 MODEL: Kodiak 700, Grizzly 700



⚠ WARNING

Please read and understand these instructions completely before installation to avoid possible injury to yourself, or damage to the accessory or vehicle.

- Overloading this ATV or carrying cargo improperly can change handling, stability, and braking performance and can lead to an accident. Never exceed the maximum front cargo limit of 180 lbs (82kg).
- Never sit on the carrier or cargo box.

WARRANTY INFORMATION:

Genuine Yamaha Accessories are covered by a one-year limited warranty against defects in material or workmanship. Labor for replacement of defective components is not covered. See your Yamaha dealer for a copy of the warranty statement.

DEALER OR INSTALLER:

These instructions contain important information for future reference and *must* be given to the customer.

NOTICE:

This installation requires a torque wrench and should be performed by an authorized Yamaha dealer or other qualified technician.

PARTS LIST:

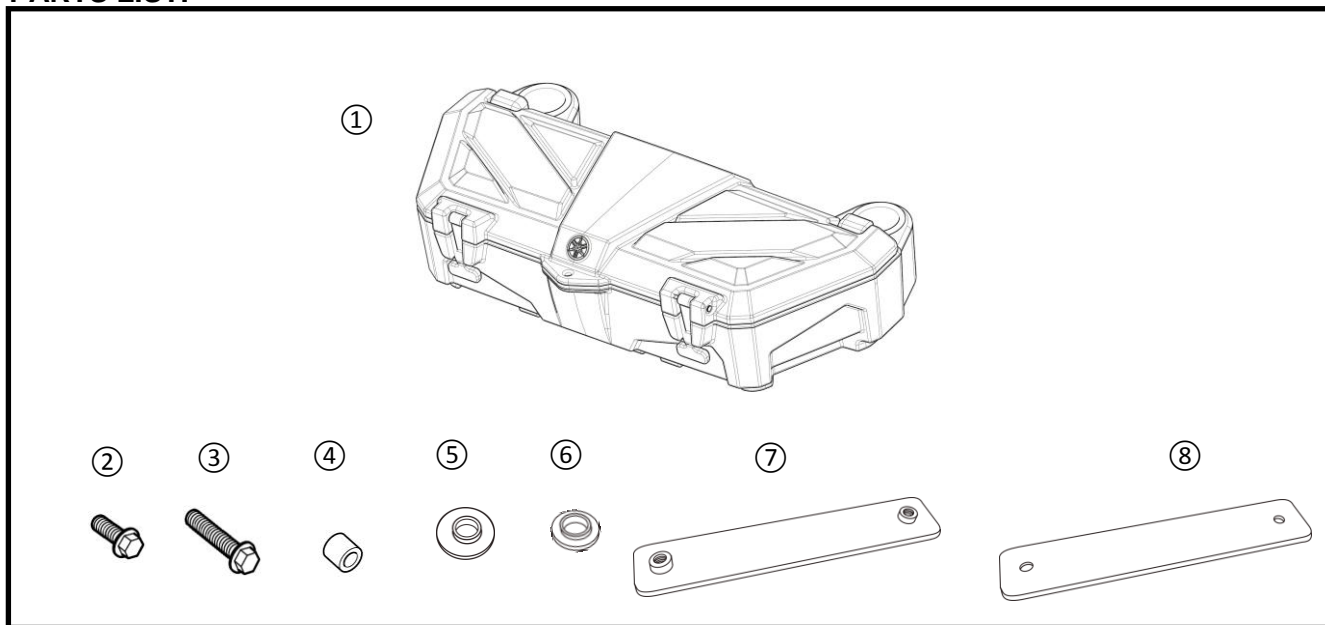

No.	Part Number	Description	Qty
*	B16-F83P0-V0	Front Cargo Box Kit	--
①	*	Front Cargo Box	1
②	*	M6 Flange Bolt x 16mm	4
③	*	M8 Flange Bolt x 30mm	2
④	*	Spacer	2
⑤	*	6mm Collar	4
⑥	*	8mm Collar	2
⑦	*	Strap	2
⑧	*	Rubber Plate	2

* Part supplied with kit only and not available separately.

Fig. 1

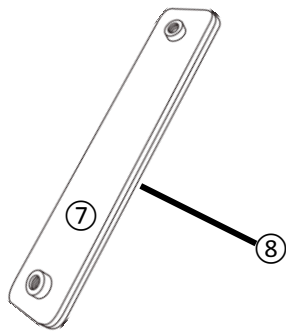
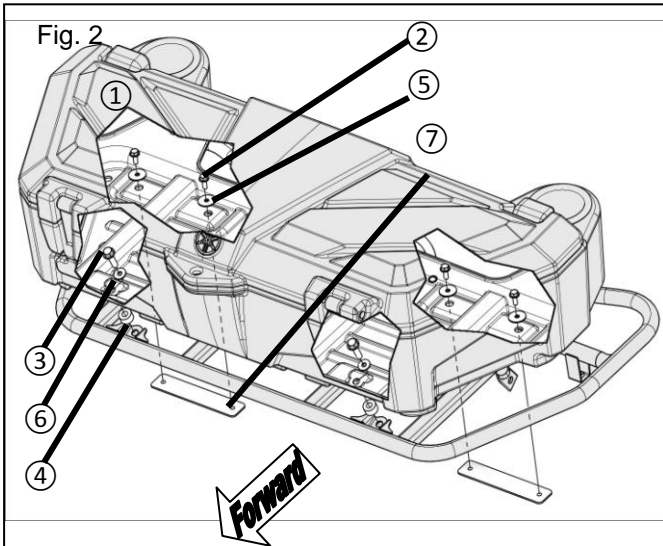

Fig. 2



PREPARATION:

- Place vehicle on a secure and level surface.
- Set the parking brake.
- Clean all mounting surfaces before installation.

INSTALLATION:

1. Peel the paper from the adhesive on the Rubber Plates (8). Align holes in the Rubber Plates (8) with the holes in the Mount Straps (7) to attach the Rubber Plates (8) to the Mount Straps (7) as shown in Fig. 1.
2. Remove 2 M8 bolts that hold the rack to the rack support. This hardware will not be reused.
3. Place the Front Cargo Box on the front rack of the vehicle and open the lid.
4. Align the mount holes that pass through the front box to the threaded nuts attached to the front rack support.
5. Starting in the left front of the Front Cargo Box, install an 8mm Collar (6) to a M8 Flange Bolt x 30mm (3) and pass the bolt through the drilled hole in the front of the box, as shown in Fig. 2.
6. Install a Spacer (4) between the Front Cargo Box (1) and the front rack and pass the bolt through the spacer. Thread the M8 Flange Bolt x 30mm into the weld nut and hand tighten. Repeat for the right front.
7. Starting in the left front of the Front Cargo Box (1), install a 6mm collar (5) to a M6 Flange Bolt x 16mm (2) and pass the M6 Flange Bolt (2) through the drill hole in the front of the Front Cargo Box (1) as shown in Fig. 2.
8. Position the Mount Strap (7)+(8) so that the Rubber Plate (8) contacts the front rack. Thread the M6 Flange Bolt x 16mm (2) into the weld nut in the Mount Strap (7) and hand tighten. Repeat for the other two holes used to secure the Front Cargo Box to the front rack.
9. Torque 8mm bolts to 33 Nm (3.3 Kgf-m, 24 Ft-lbf). Torque 6mm bolts to 10Nm (1.0 Kgf-m, 7.4 Ft-lbf).

MAINTENANCE:

Check and adjust as necessary.

CARE AND CLEANING:

Wash with a mild soap and water solution using a soft cloth.

CUSTOMER SERVICE:

For further information see your Yamaha dealer.

ESTIMATED TIME TO INSTALL: 0.4 HRS